

13	12	11	10	9	8	7	6	5	4	3	2	1
PART NUMBER	PRODUCT DESCRIPTION					FRONT SHELL PLATING						
71691-0003	60ckt I/O RECEPTACLE CONNECTOR SUB-ASSEMBLY					BRIGHT TIN						
71691-9003	60ckt I/O RECEPTACLE CONNECTOR SUB-ASSEMBLY					BRIGHT NICKEL						

**NOTES:**

- DAMAGE OF THE CONTACT FINGERS DURING THE ASSEMBLY OPERATION IS UNACCEPTABLE. CORRECT ALIGNMENT OF THE TERMINAL STRIP ASSEMBLIES, PRIOR TO AND DURING ASSEMBLY IS NECESSARY TO AVOID DAMAGE.
- PLASTIC HOUSING:  
GLASS FILLED LCP (LIQUID CRYSTAL POLYMER), UL 94 V-0, COLOR: BLACK.
- FRONT SHELL:  
DEEP DRAWN STEEL, .016" THICK;  
PLATING: SEE TABLE  
BRIGHT TIN: 150-250 MICROINCHES BRIGHT TIN OVER 50-150 MICROINCHES NICKEL OVER COPPER FLASH OVERALL (OPTIONAL).  
BRIGHT NICKEL: 100-175 MICROINCHES BRIGHT NICKEL OVER 50 MICROINCHES MAXIMUM COPPER OVERALL.
- BACK SHELL:  
DEEP DRAWN STEEL, .016" THICK;  
PLATING: 150-250 MICROINCHES BRIGHT TIN OVER 50-150 MICROINCHES NICKEL OVER COPPER FLASH OVERALL (OPTIONAL).
- THIS PRODUCT CONFORMS TO PRODUCT SPECIFICATION PS-70928.
- INSERT-MOLDED TERMINAL STRIP ASSEMBLIES ARE SUPPLIED SEPARATELY (SEE SHEET 2 FOR ORDERING INFORMATION).
- PACKAGING SPECIFICATION PK-70873-0236 APPLIES.

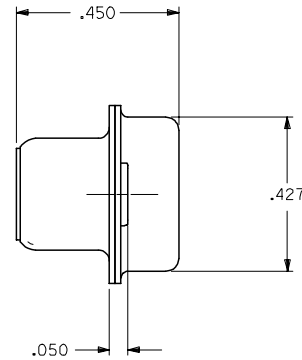
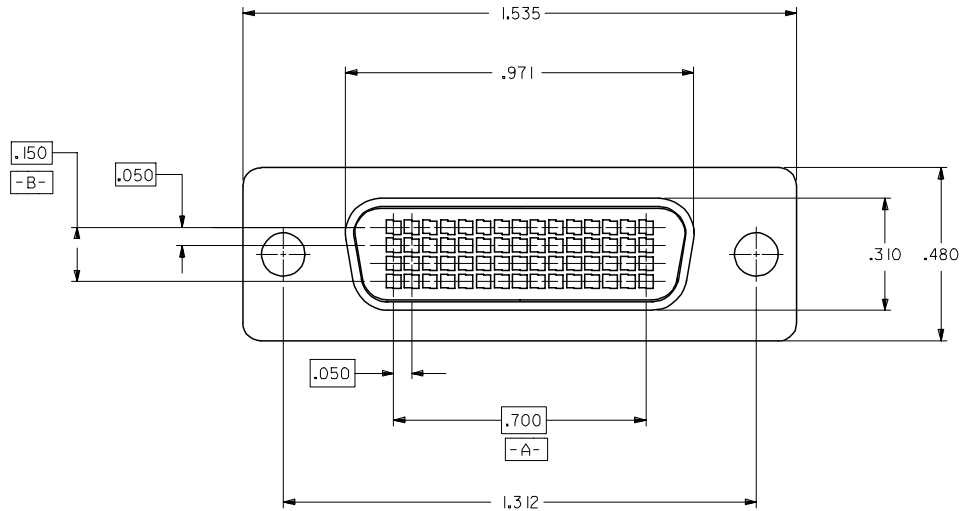
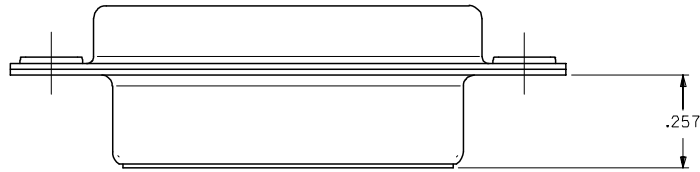

2	A
1	C
SHT	REV

ADD 71691-9003 EC NO: UCP2006-0666 DRAWN BY: BARRA 2006/02/06 CHKD: MORGAN 2006/02/07 APPR: MILLER 2006/02/09	QUALITY SYMBOLS ▽=0 ▽=0	GENERAL TOLERANCES (UNLESS SPECIFIED)		DIMENSION STYLE INCH ONLY		SCALE 4:1	DESIGN UNITS INCH	THIRD ANGLE PROJECTION	
		mm	INCH	DRAWN BY	DATE	TITLE			
		4 PLACES ± ---	± ---	SCHMIDGALL	93/08/04	.050 PITCH LFH			
		3 PLACES ± ---	± ---	CHECKED BY	DATE	60 CKT I/O SALES ASSEMBLY			
2 PLACES ± ---	± ---	OSULLIVAN	93/08/04	APPROVED BY		DATE	MATERIAL NO. DOCUMENT NO. SHEET NO.		
1 PLACE ± ---	± ---	ANGULAR ±1/2°		BIXLER	93/08/04	SDA-71691-0003		1 OF 2	
DRAFT WHERE APPLICABLE MUST REMAIN WITHIN DIMENSIONS		SEE TABLE		THIS DRAWING CONTAINS INFORMATION THAT IS PROPRIETARY TO MOLEX INCORPORATED AND SHOULD NOT BE USED WITHOUT WRITTEN PERMISSION					

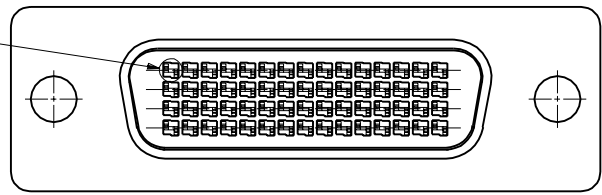
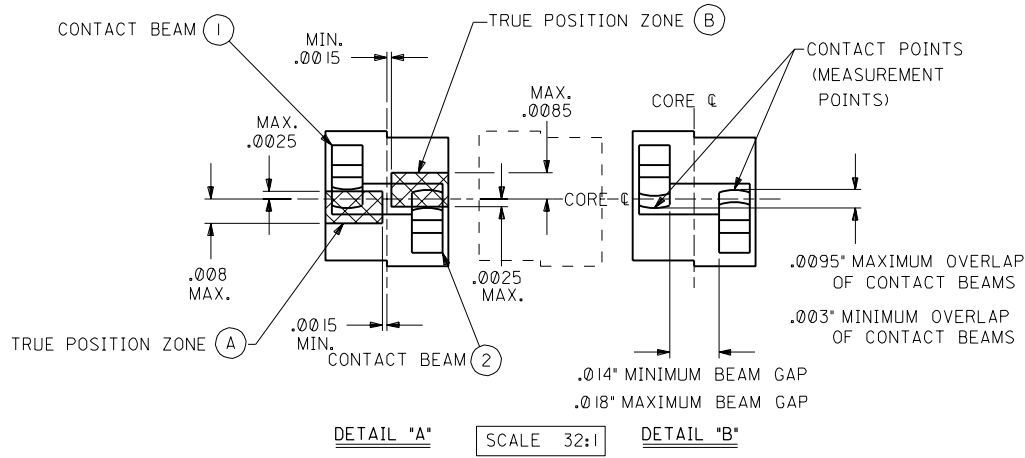

CONTACT TRUE POSITION REQUIREMENTS

- \* CONTACT BEAM ① MAY BE LOCATED ANYWHERE WITHIN THE BOUNDARIES OF TRUE POSITION ZONE (A) PROVIDED THAT THE CONDITIONS OF DETAIL "B" ARE MET.
- \* CONTACT BEAM ② MAY BE LOCATED ANYWHERE WITHIN THE BOUNDARIES OF TRUE POSITION ZONE (B) PROVIDED THAT THE CONDITIONS OF DETAIL "B" ARE MET.

NOTE: ALL TRUE POSITION MEASUREMENTS TO BE TAKEN AT CONTACT POINTS, NOT AT CONTACT TIPS. ALL TRUE POSITION ZONES ARE TO BE DEFINED RELATIVE TO THE HOUSING CORE CENTERLINES.

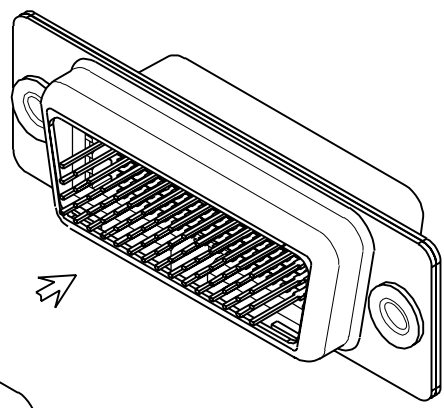

STEP 1.  
STACK 4 STRIP ASSEMBLIES AS SHOWN

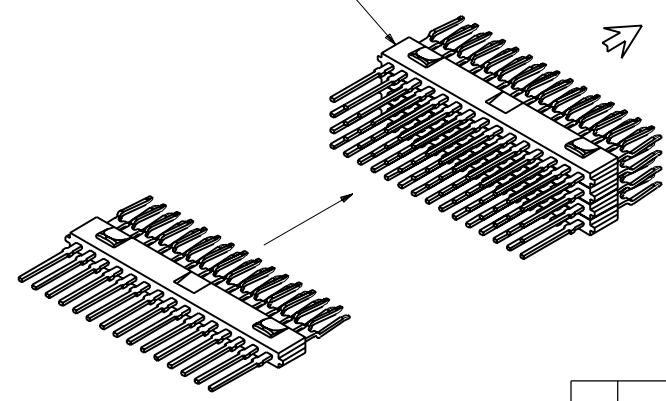

STEP 2.  
AFTER TERMINATION, ASSEMBLE THE STACKED STRIP ASSEMBLIES INTO THE CONNECTOR HOUSING, ENSURING THAT THE LATCHES ARE CORRECTLY ORIENTATED AND SEATED.

INSERT-MOLDED TERMINAL STICKS  
FOUR REQUIRED PER ASSEMBLY  
(SEE SALES DRAWING: SDA-70985-100\*)

DIMENSIONS SHOWN (METRIC) INCH UNLESS OTHERWISE SPECIFIED TOLERANCES: ANGULAR ± 1/2°		▽ = 0 ▼ = 0		REVISE ONLY ON CAD SYSTEM	
5 PLACE ± --- ---	INCH	METRIC	TITLE .050" PITCH LFH 60 ckt I/O SALES ASSEMBLY		
2 PLACE ± --- ± ---			MOLEX INCORPORATED SHEET NO. DATE L15LE.JLL. 60532 U.S.A. 2 08/04/93		
1 PLACE --- ± ---			PART NO. DRWG. NO. SEE SHEET 1 SDA-71691-0003		
DRAFT WHERE APPLICABLE MUST REMAIN WITHIN DIMENSIONS		THIS DRAWING CONTAINS INFORMATION THAT IS PROPRIETARY TO MOLEX INC. AND SHOULD NOT BE USED WITHOUT WRITTEN PERMISSION.			
DRW'G. BY: SCHMIDGALL	CHK'D. BY: OSULLIVAN	FILE NAME: S71691X2	APP'D. BY: BIXLER	SCALE: 4:1	SIZE: CD
LTR.	REVISIONS	LTR.	REVISIONS	A	SEE SHEET 1